

**C 325BEE**

**STEREO  
AMPLIFIER**

**SERVICE MANUAL**

downloaded from <http://receiverfaq.ru/>

**C 325BEE**

**STEREO  
AMPLIFIER**

**NAD**

WIRING DIAGRAM

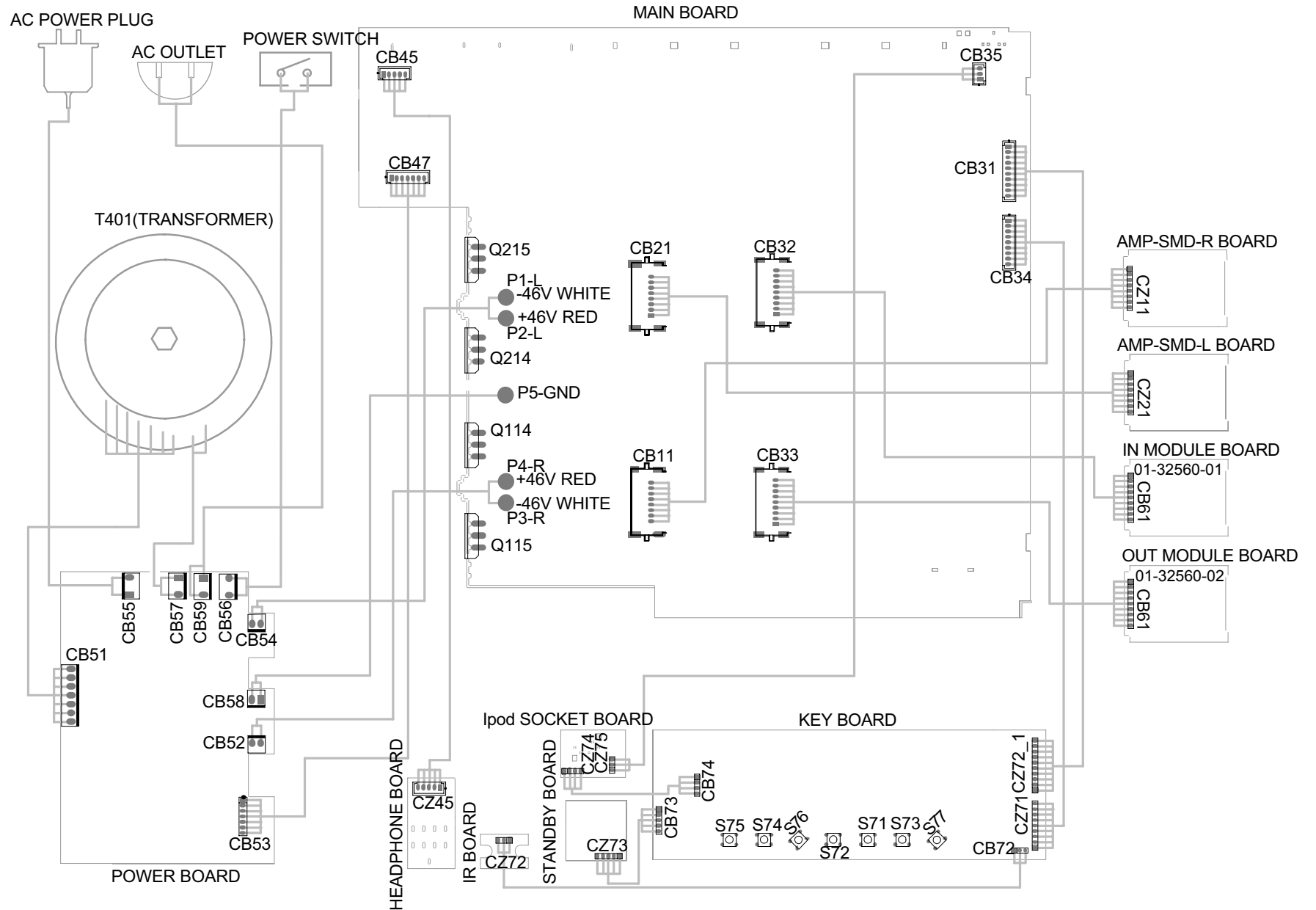

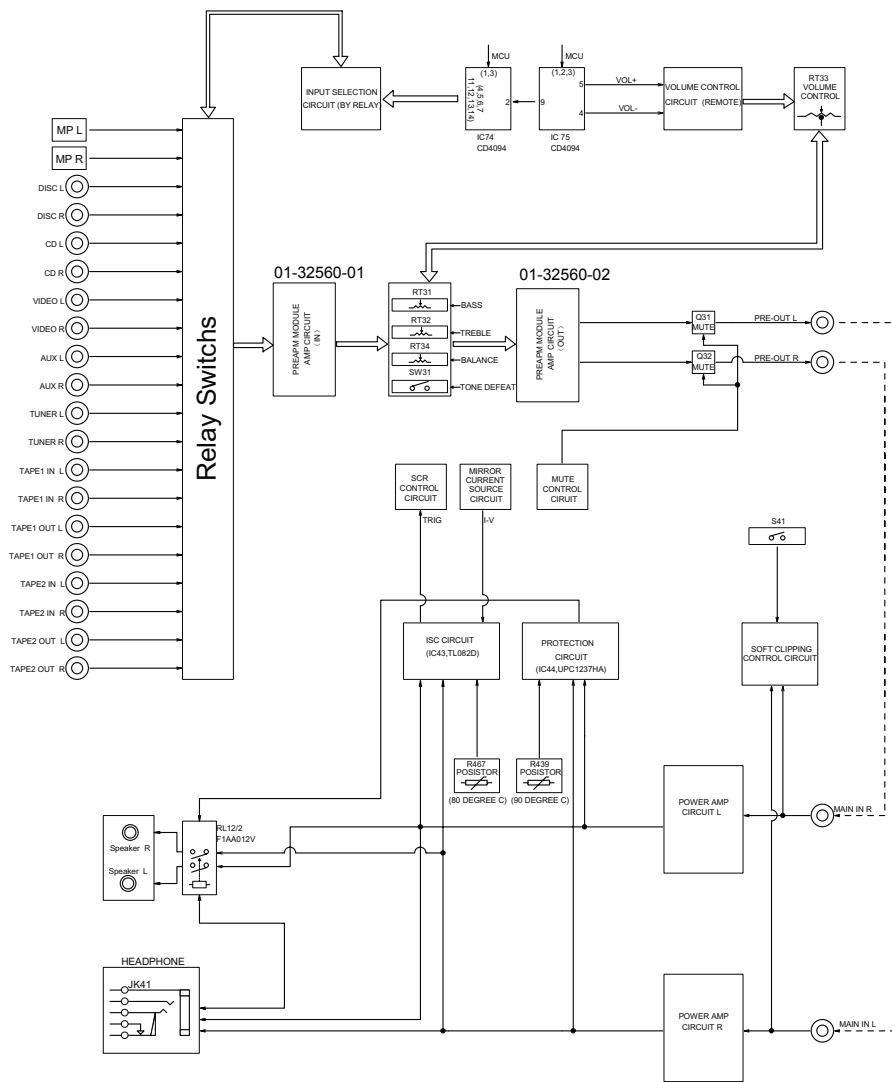

BLOCK DIAGRAM

# MICROPROCESSOR CONNECTION DIAGRAM

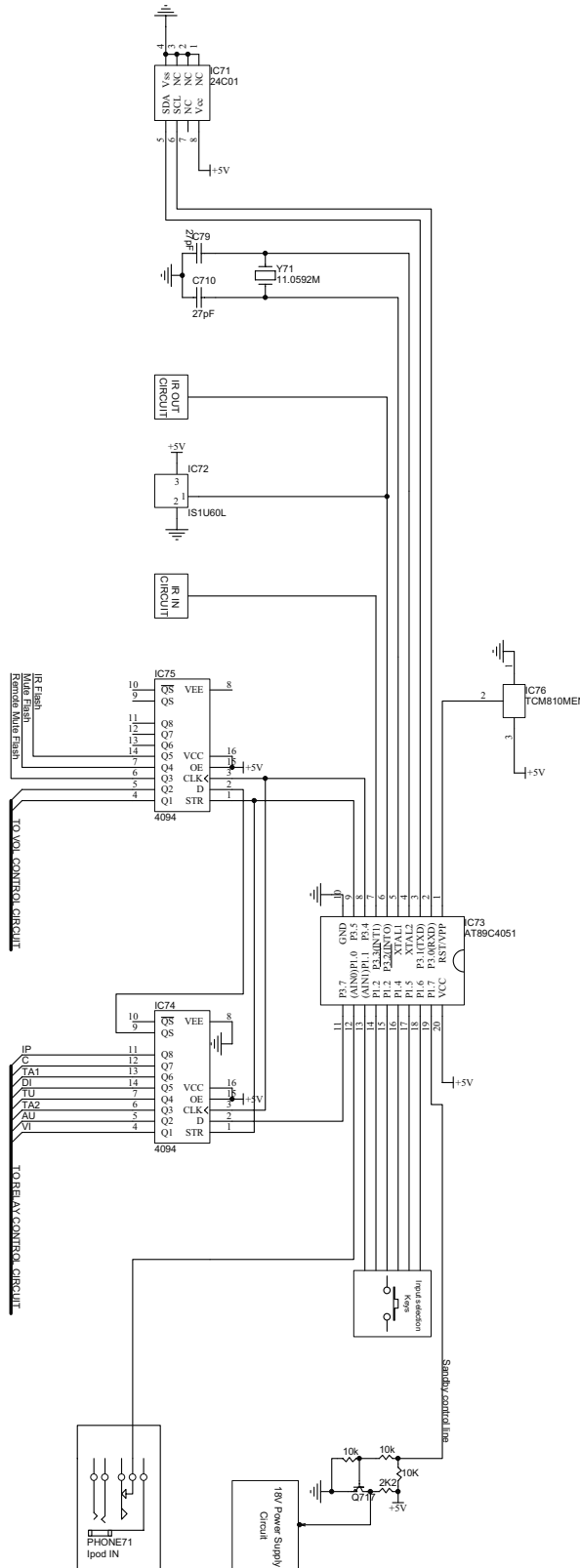

SCHEMATICS DIAGRAM

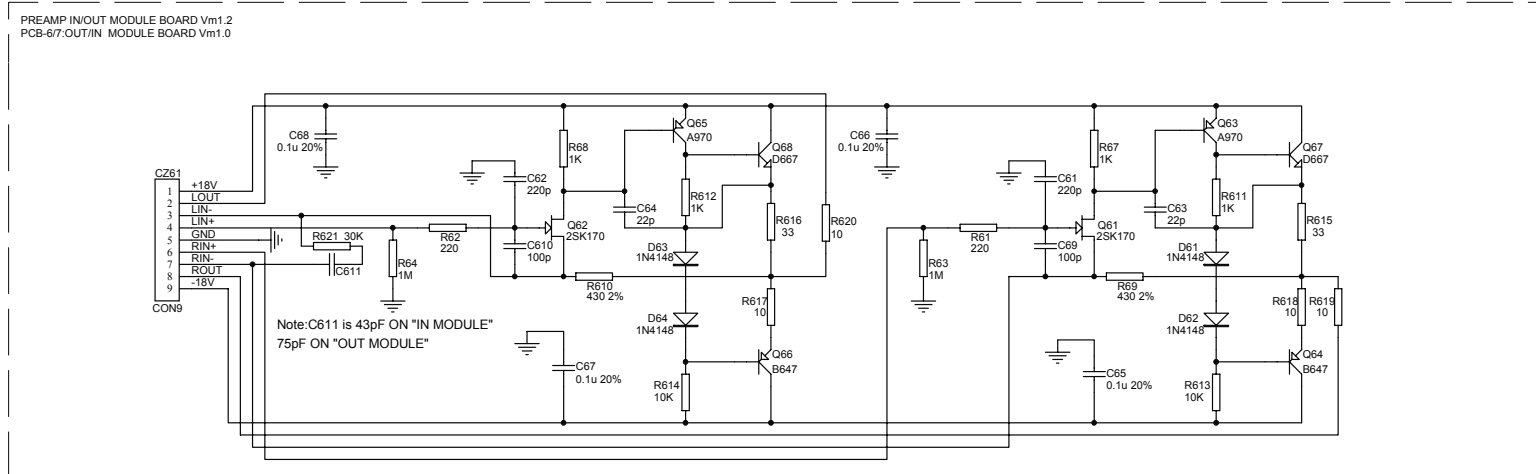
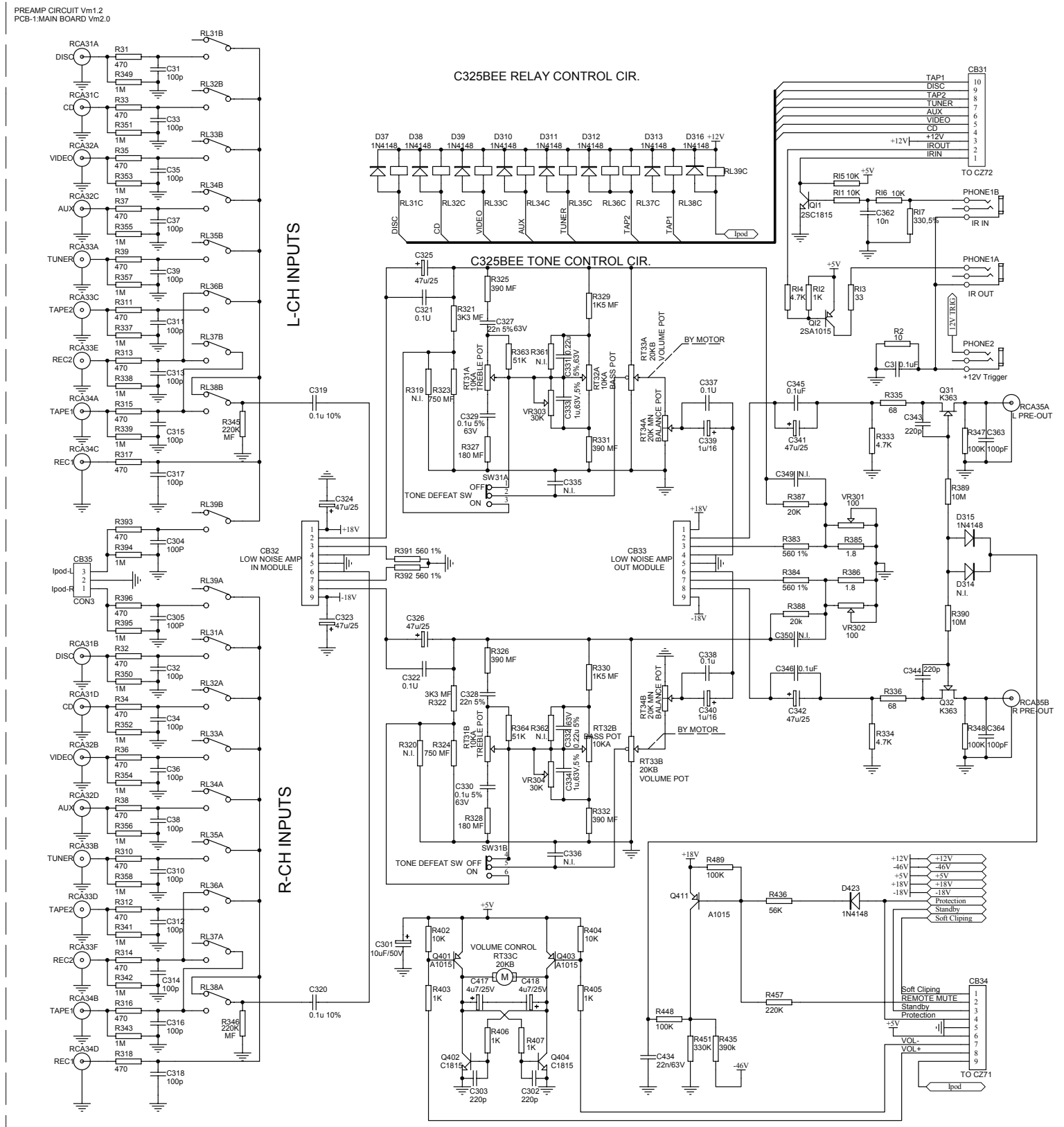

SCHEMATICS DIAGRAM(1/4)

AMP CIRCUIT Vnt.4  
PCB-1MAIN BACRD Vnt.2

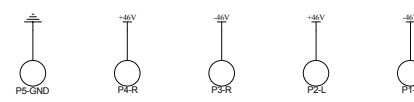
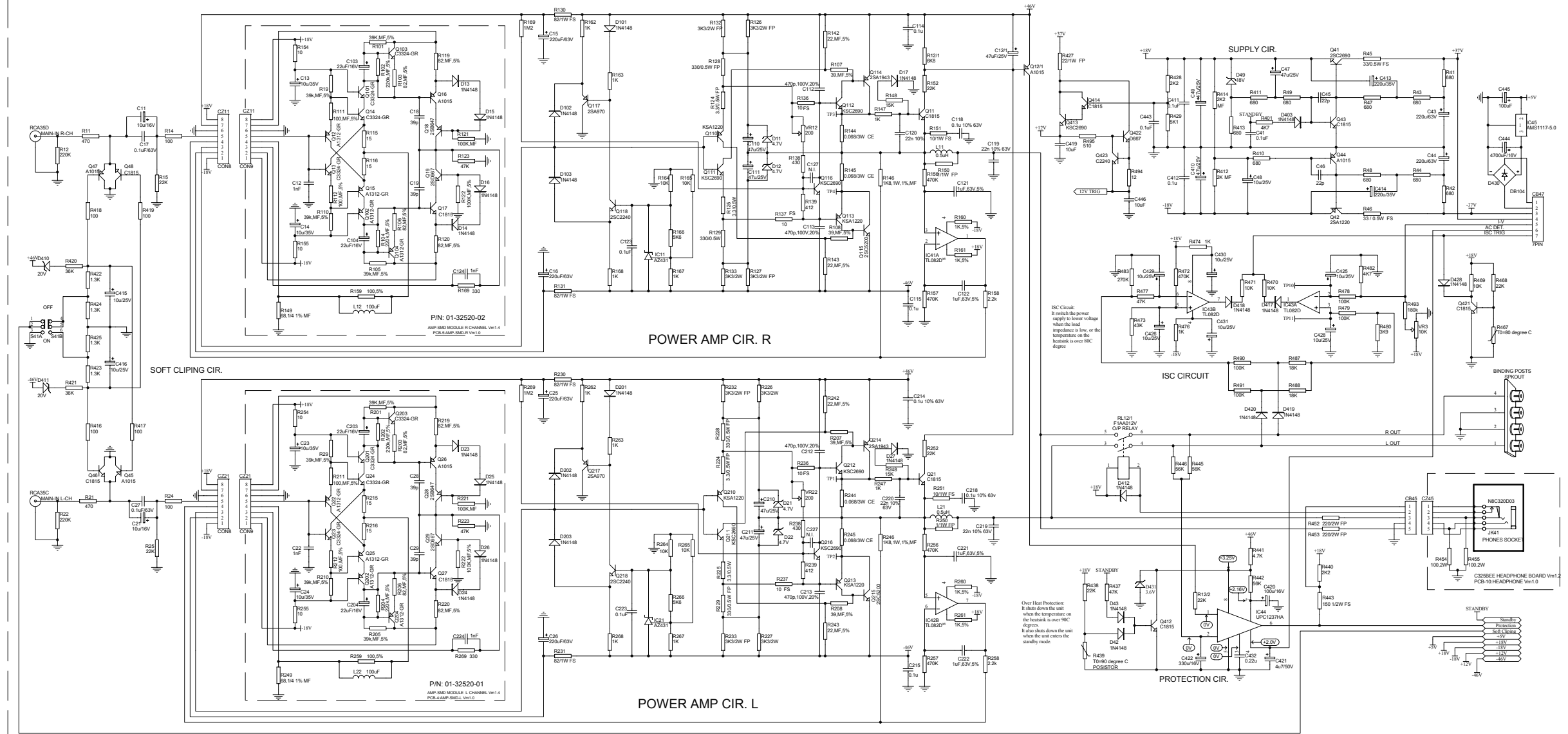

SCHEMATICS DIAGRAM(4/4)

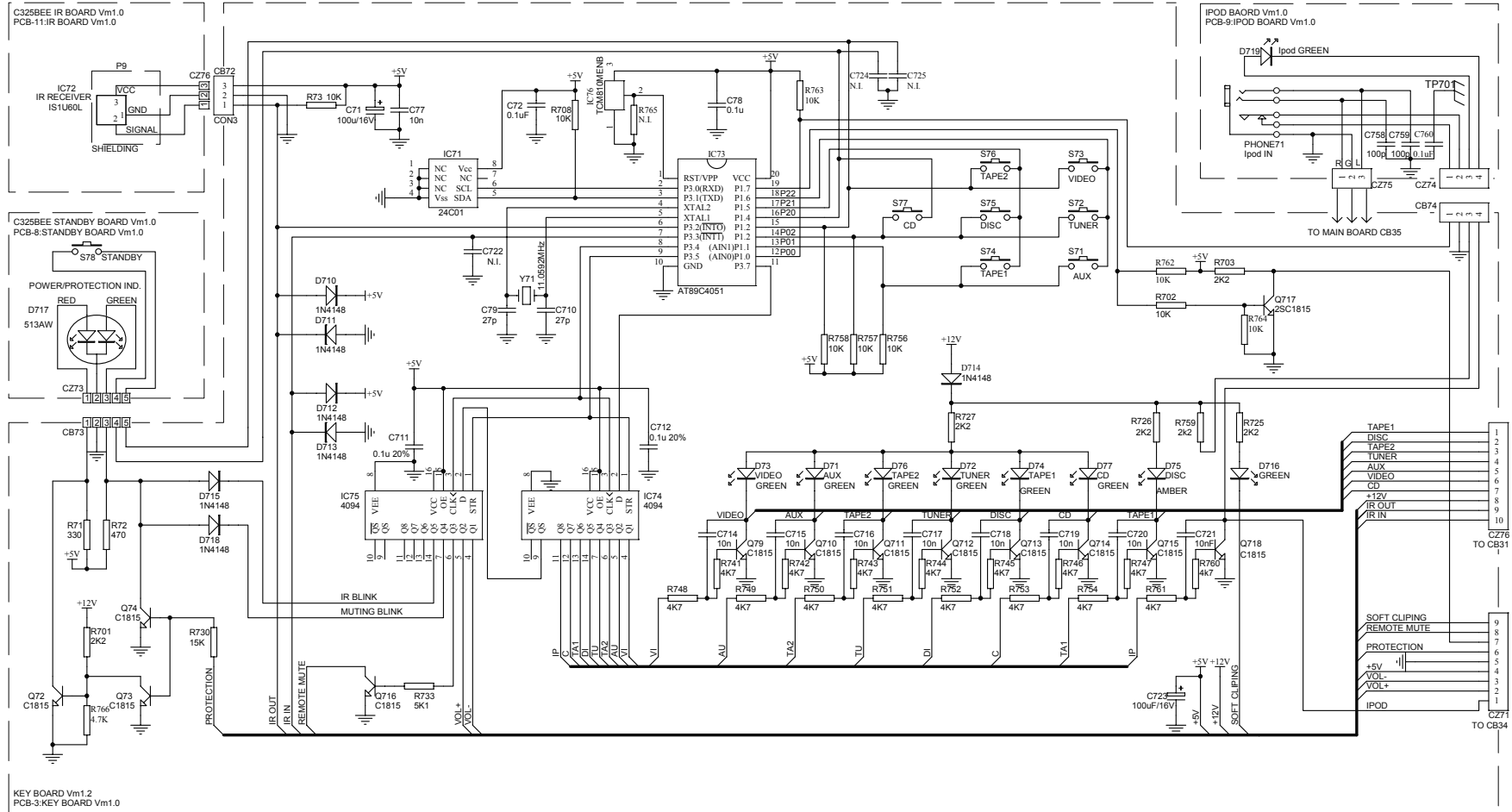

SCHEMATICS DIAGRAM (3/4)

POWER CIRCUIT Vm1.2  
PCB-2:POWER BOARD Vm2.0

